

**Hand Stacker**

**EPS 0516**  
**EPS 1016**  
**EPS 1516**  
**EPS 2016**

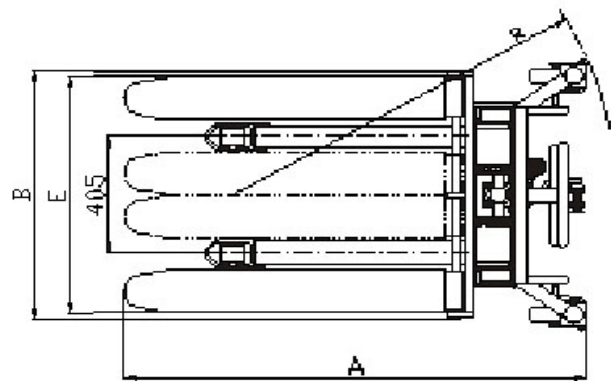

**EPS 1025**  
**EPS 1029**

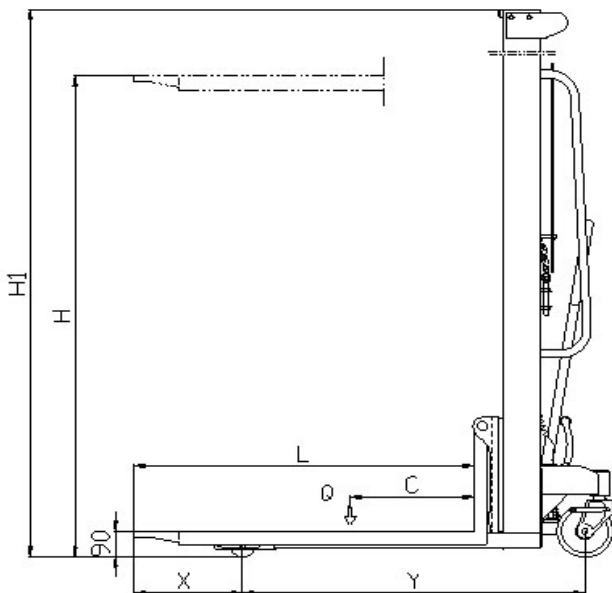

รายละเอียดผลิตภัณฑ์อาจมีการเปลี่ยนแปลงโดยมิได้แจ้งให้ทราบล่วงหน้า

## HAND STACKER

รายละเอียดผลิตภัณฑ์อาจจะมีการเปลี่ยนแปลงโดนมิแจ้งให้ทราบล่วงหน้า

รุ่น ยกสูง 1.6m มีรุ่นยกน้ำหนัก 500,1000,1500,2000 kg

Technical Data		Model			
		EPS 0516	EPS 1016	EPS 1516	EPS 2016
Capacity	KG	500	1000	1500	2000
Maximum Fork Height	mm	1600			
Minimum Fork Height	mm	88		90	
Fork Width	mm	160			
Fork Length	mm	1150			
Overall Fork Width	mm	320-860	320-700		
Load Roller	mm	Ø 80 x 70 (Nylon)			
Steering Wheel	mm	Ø 180 x 50 (Nylon)			
Overall Length	mm	1765			
Overall Width	mm	900	790		
Overall Height	mm	2077			
Net Weight	Kg	200	230	250	260
Warranty Pump Unit 1 Year					
Specification is subject to change without notice					

รุ่น ยกสูง 2.5m / 2.9m มีรุ่นยกน้ำหนัก 1,000 kg

Technical Data		Model	
		EPS 1025	EPS 1029
Capacity	KG	1000	
Minimum Fork Height	mm	88	
Maximum Fork Height	mm	2500	2900
Fork Width	mm	160	
Fork Length	mm	1150	
Overall Fork Width	mm	320-700	
Load Roller	mm	Ø 80 x 70 (Nylon)	
Steering Wheel	mm	Ø 180 x 50 (Nylon)	
Overall Length	mm	1765	
Overall Width	mm	790	
Overall Height	mm	1890	2085
Net Weight	Kg	315	325
Warranty Pump Unit 1 Year			
Specification is subject to change without notice			