

Full Electric Stacker FE Series 1500 kg



- * Adjustable fork
- * Platform

- * Ergonomic Tiller Made in Germany



Full Electric Stacker FE Series 1500 kg

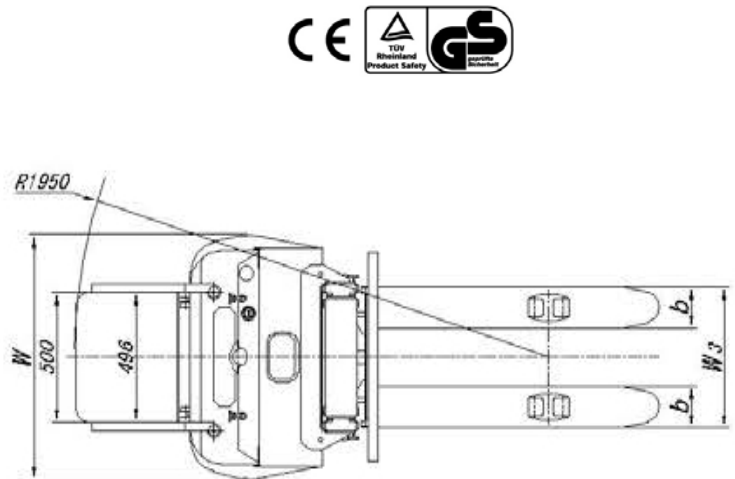
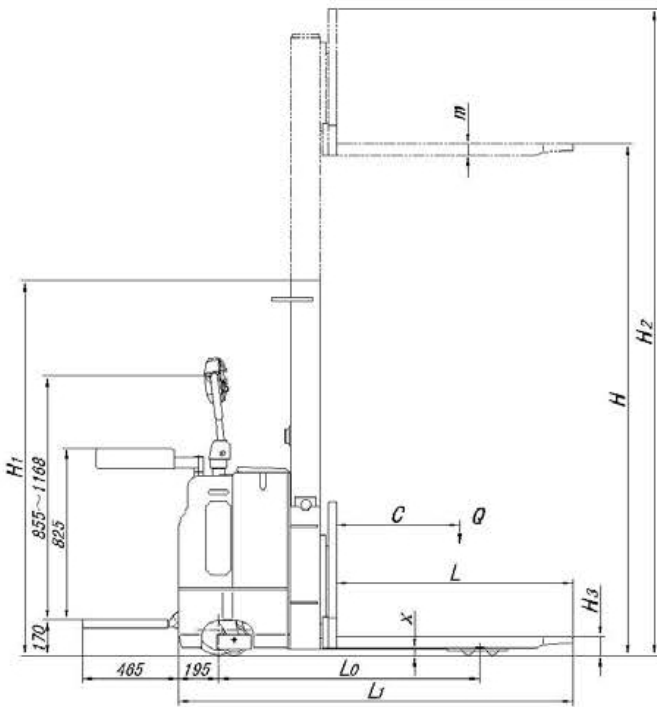

TECHNICAL DATA		MODEL			
		FE 1516	FE 1525	FE 1530	FE 1535
Capacity	Kg	1500			
Load Center	C mm	600			
Max. Fork Height	H mm	1600	2500	3000	3500
Overall Length	L1 mm	1920			
Overall Width	W mm	940			
Overall Height	H1 mm	2125	1825	2050	2325
Maximum Working Height	H2 mm	2250	3150	3600	4150
Lowered Fork Height	H3 mm	90			
Maximum Fork Width	W3 mm	540/680			
Fork Dimensions	L×b×m	1150×160×56			
Wheel Base	mm	1270			
Minimum Distance Over Ground	X mm	29			
Minimum Turning Radius	Wa mm	1505			
Aisle Width for Pallets 1000x1200 Crossways	Ast mm	2350			
Aisle Width for Pallets 800x1200 lengthways	Ast mm	2300			
Traveling Speed (loaded/unloaded)	km/h	4.0/5.5			
Lifting Speed (loaded/unloaded)	mm/s	90/160			
Lowering Speed (loaded/unloaded)	mm/s	95/120			
Front Roller, Tandem	mm	Φ78×70			
Rear Roller	mm	Φ150×75			
Driving Wheel	mm	Φ250×80			
Traction Battery	Ah/V	240/24			
Charger	A / V	16 / 24			
Traveling Motor	kw	1.2			
Lifting Motor	kw	2			
Net Weight (without battery)	kg	620	680	705	725
Battery Weight	kg	230			

SPECIFICATION IS SUBJECT TO CHANGE WITHOUT NOTICE