

Electric Mobile Tilt Table

- ▲ Lifts heavy loads with ease.
- ▲ Allow an operator to feed and unload parts from tote boxes or containers quickly without bending down or up, stretching or reaching.
- ▲ Power unit made in Europe, DC 700W.
- ▲ High quality battery service free 75Ah/12V.
- ▲ A separate automatic charger.
- ▲ Two brakes on steering wheel increase safety.
- ▲ Wheel Diameter: 150mm, handle height 1180mm.

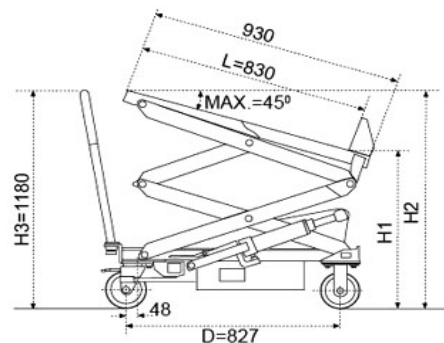

รายละเอียดผลิตภัณฑ์อาจมีการเปลี่ยนแปลงโดยมิได้แจ้งให้ทราบล่วงหน้า

TECHNICAL DATA		MODEL	
		TS 40	TS 80
Capacity	kg.	400	800
Table Size	L x W mm.	830 x 520	
Dimensions	M mm.	930	
Dimensions	N mm.	830	
Table Height min / max	H1 mm.	500 / 990	500 / 1620
Table Height min / max	H2 mm.	500 / 1000	500 / 1620
Handle Height	H3 mm.	1180	
Wheel Diameter	mm.	Ø 150	
Overall Size	B x C mm.	520 / 1185	520 / 1260
Time to Max.Height	second	20	
Power Unit		DC 700 W	
Battery		75 Ah / 12 V	
Net Weight	kg.	170	185

SPECIFICATION IS SUBJECT TO CHANGE WITHOUT NOTICE