

Galvanized Hand Pallet Truck

- ▲ Latest galvanizing technology offers longest span life and prevent corrosion.
- ▲ For use in corrosive environment, cold room or clean room applications.
- ▲ Chrome plated piston and valve.
- ▲ Galvanized structure including fork frame, wheel frame, push rod, handle.
- ▲ Galvanized pump with leak resistant and airless design.
- ▲ 75mm (3") lowered fork height available.
- ▲ Conforms to EN1757-2.

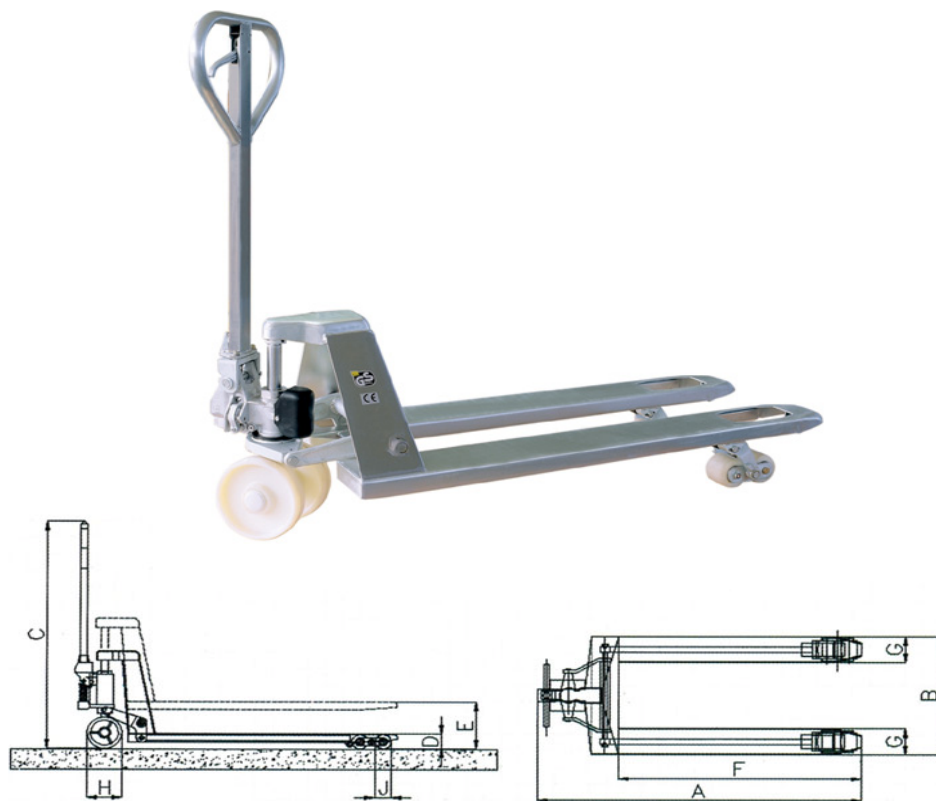

รายละเอียดผลิตภัณฑ์อาจมีการเปลี่ยนแปลงโดยมิได้แจ้งให้ทราบล่วงหน้า

TECHNICAL DATA		MODEL			
		PHG 255	PHG 256	PHG 305	PHG 306
Capacity	kg	2500		3000	
Overall Length	A mm	1550			
Width Overall Fork	B mm	540	680	540	680
Overall Height	C mm	1220			
Min.Fork Height	D mm	85			
Max.Fork Height	E mm	205			
Fork Length	F mm	1150			
Individual Fork Width	G mm	160			
Steering Wheel Diameter	H mm	Ø 200 x 50 (Nylon)			
Load Roller Diameter	J mm	Ø 80 x 70 (Nylon)			
Net Weight	kg	76	78	80	83

SPECIFICATION IS SUBJECT TO CHANGE WITHOUT NOTICE