

Tift & Tift Table

- ▲ The Lift &Tilt Tables from HU-LIFT are specifically designed to allow an operator to feed and unload parts from tote boxes or containers quickly and easily without lifting, bending, stretching, or reaching.
- ▲ When in its lift and tilt position, the unit holds totes or containers at a comfortable working height and angle that allows operators to easily reach parts even at the bottom of the container.
- ▲ The working table is elevated by means of a foot actuated hydraulic cylinder. As the table is raised, it automatically tilts to an angle of 45° at full elevation. Built-in retaining lip keeps containers in place.

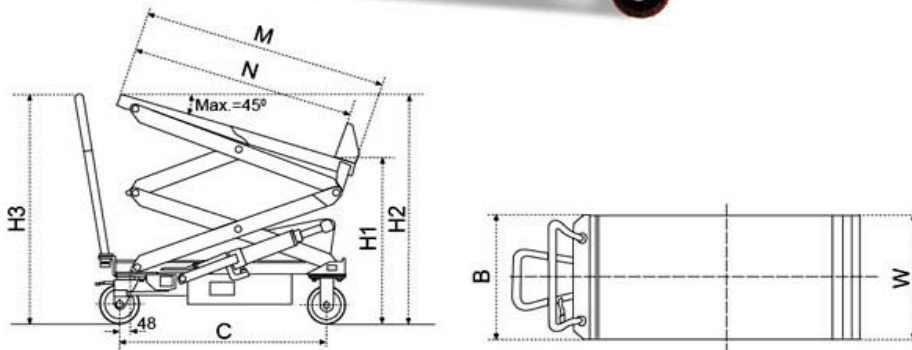

รายละเอียดผลิตภัณฑ์อาจมีการเปลี่ยนแปลงโดยมิได้แจ้งให้ทราบล่วงหน้า

TECHNICAL DATA		MODEL	
		BL 40	BL 80
Capacity	kg.	400	800
Table Size	L x W mm.	830 x 520	
Dimensions	M mm.	930	
Dimensions	N mm.	830	
Table Height	min / max	H1 mm.	435 / 900
Table Height	min / max	H2 mm.	435 / 1560
Handle Height		H3 mm.	1130
Wheel Diameter		mm.	Ø 150
Overall Size	B x C mm.	520 x 1355	
Foot Pedal to Max.Height	mm.	55	80
Power Unit		/	
Battery			
Net Weight	kg.	123	145

SPECIFICATION IS SUBJECT TO CHANGE WITHOUT NOTICE